



IBL3605 - 5A INTELIGENTNÝ STUPEŇ OVLÁDAČA

4603605040

IBL3605 Inteligentné ovládanie 36V 5A RS232



TECHNOSOFT
MOTION TECHNOLOGY

- Až 180W, 5A nepretržitý 16A špičkový, 12-42VDC
- DC, Brushless alebo krokový motor s rovnakým ovládaním
- Komunikácia cez RS232 a TML-CAN alebo CANopen
- Môže fungovať ako rozhranie RS232 na CAN



EasyMotion Studio compatible
Visual C / VB / LabVIEW / Linux
and PLC libraries available

POPIS PRODUKTU

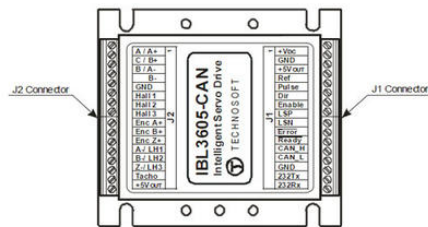
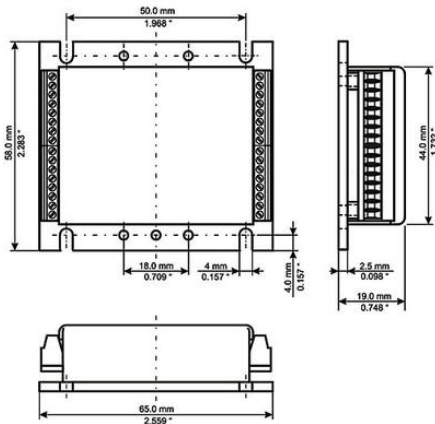

Figure 3.1. IBL3605 drive connectors

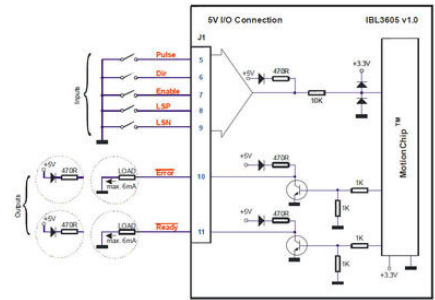

Figure 3.8. 5V Digital I/O connection

Remarks:

1. The inputs are compatible with NPN type outputs.
2. The outputs are compatible with TTL (5V) and NPN (24V) inputs